



FIXING BY UNDERCUT TECHNIQUE





SSC - University of Cologne, Cologne, DE © KEIL

High-quality façade panels transform dreary buildings into fascinating objects. Architects will face creative design possibilities. The underlying secret is the invisible attachment by an elaborate fixing device called undercut technique.

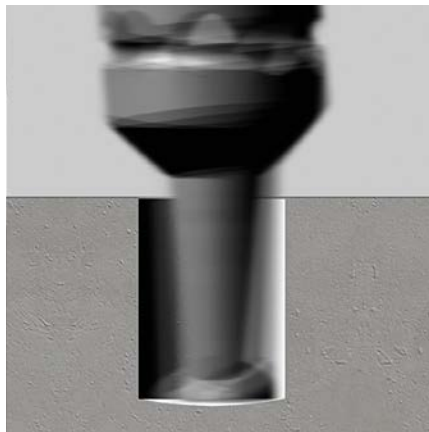
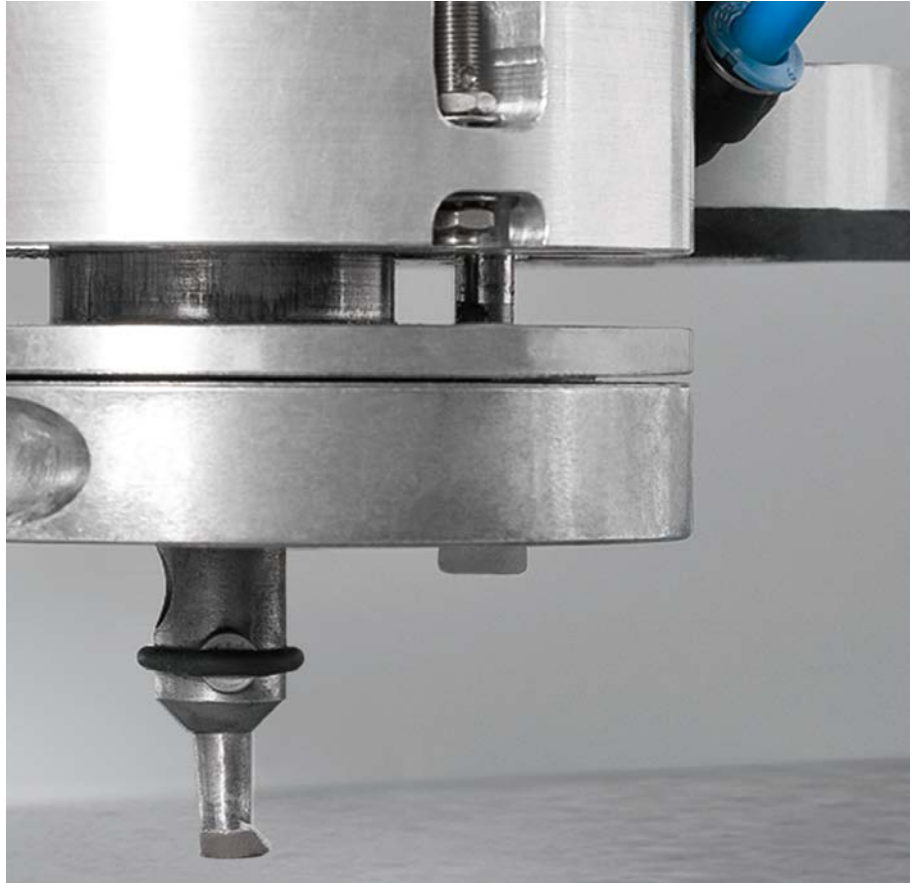

Drilling

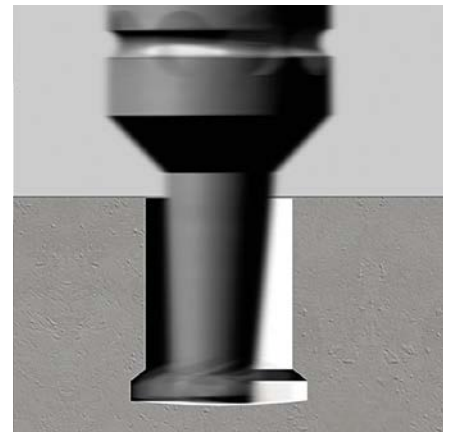

Undercutting

- ▶ Cylindrical drilling and conical undercutting are carried out in one single process and by only one tool.
- ▶ Different levels of automation are possible, depending on the type of machinery and the material of the panel.
- ▶ Drilling time for ceramics is less than 10 seconds.
- ▶ Panels of any desired size and weight will get a patented undercut in a precise and consistent symmetric shape.

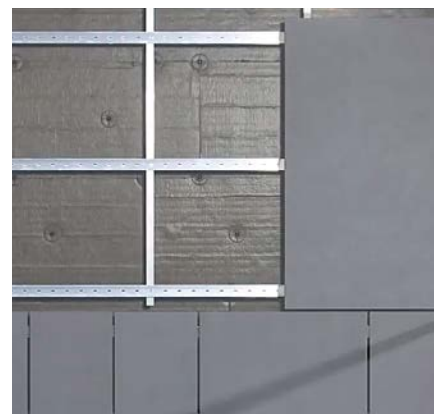

SSC - University of Cologne, Cologne, DE © KEIL

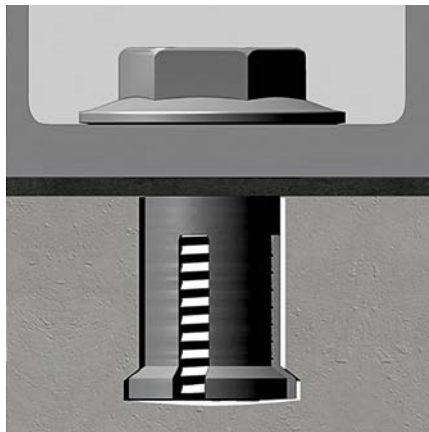
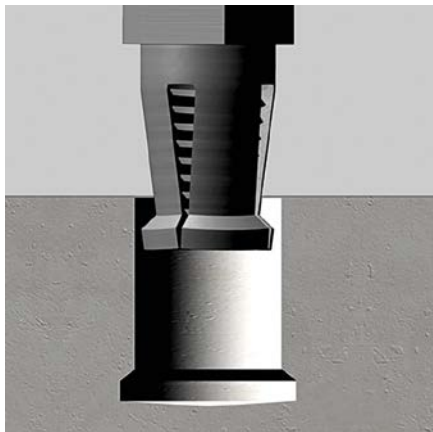

Assembly

The undercut technique is as simple as it is ingenious. By means of a patented drilling system a blind hole with an expanded base is drilled into the backside of the façade panel. Subsequently, the KEIL undercut façade anchor is inserted into the hole. This anchor guarantees a positive-locking attachment, which is free of expansion force. As soon as the panel is equipped with brackets, it can be mounted directly on to the substructure.

- ▶ For the assembly, an undercut anchor is inserted into the hole and locked positively by a screw.
- ▶ The assembly is fast, safe and simple.

Insertion depths



$h_s = 4,0 \text{ mm}$

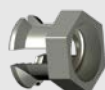

$h_s = 5,5 \text{ mm}$

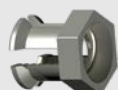

$h_s = 7,0 \text{ mm}$

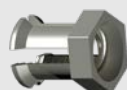

$h_s = 8,5 \text{ mm}$

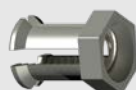

$h_s = 10,0 \text{ mm}$



$h_s = 11,5 \text{ mm}$



$h_s = 13,0 \text{ mm}$



$h_s = 15 \text{ mm}$

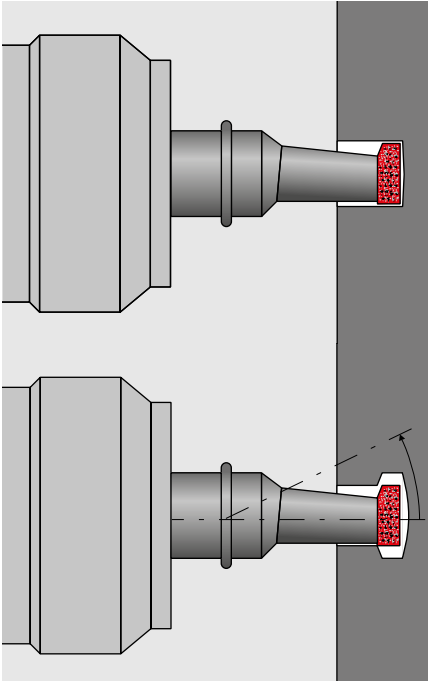

Drilling and undercutting in one step

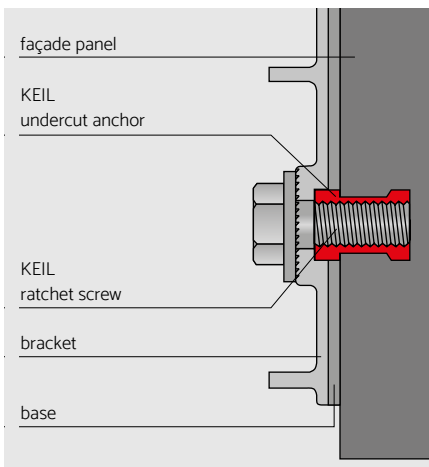

Structure

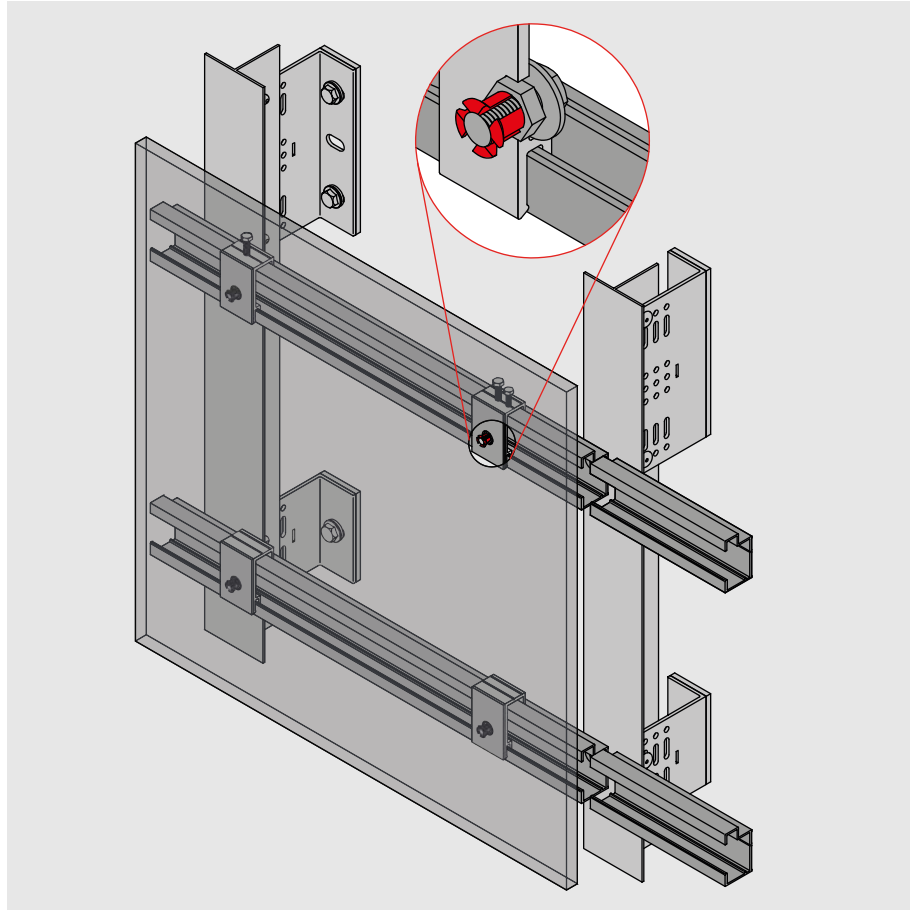

The KEIL undercut drilling

Cylindrical drilling and conical undercutting are carried out with only one tool and in one single step. Different levels of automation are possible, depending on the type of machinery and material. Drilling time in ceramics is less than 10 seconds. Panels of any size and weight will get a patented undercutting with a precise and consistent symmetric shape. For a cylindrical drilling with a diameter of $\varnothing 7$ mm, the diameter of the undercut will be $\varnothing 9$ mm. For the assembly, the undercut anchor is placed in the drill hole and locked positively with a screw. Quick, simple and safe, with customary tools, e.g. cordless screwdrivers.

The KEIL undercut anchor

The KEIL undercut anchor for the hidden attachment of thin panels is manufactured from stainless steel. Its geometry, which matches the KEIL undercut drill hole, guarantees an attachment free from expansion pressure in all common panel materials from a panel thickness of 6 mm onwards. Different insertion depths are possible, depending on the thickness of the panel or the necessary bearing capacity. The KEIL undercut anchor is designed to carry more weight than that of the panel material. Due to its high assembly safety, the KEIL undercut anchor offers significant advantages. The displacement-controlled assembly of the anchor in all panel thicknesses will be carried out quickly, simply and safely with the aid of the coordinated KEIL system: anchor, bracket and KEIL ratchet screw with integrated screw lock. Only two parts (anchor sleeve and screw) are necessary for a secure fastening. Other screw-in parts for the KEIL undercut anchor allow for your individual connection variant, e.g.:

- ▶ connection to substructures
- ▶ connection to cassette designs
- ▶ attachment to reveal panels with interior angles
- ▶ direct attachment to the wall with fork or plug-in anchors
- ▶ fixing of wash basins, work tops, furniture, grave borders or radiators made from natural stone

Safety instructions

Safety and product liability require, that the KEIL undercut fixing system must always be used as one unit. The function will only be guaranteed, if the coordinated KEIL products (anchor with screw or grub screw, chuck and façade drill) are used in combination. The use as a system is also regulated in the approvals hitherto granted resp. applied for. Parts of the KEIL undercut fixing system are patented.



Undercut anchors

KEIL undercut anchors attach façade panels securely and invisibly to the substructure. Our high-quality fixing elements are available in different designs and with matching spacer discs.

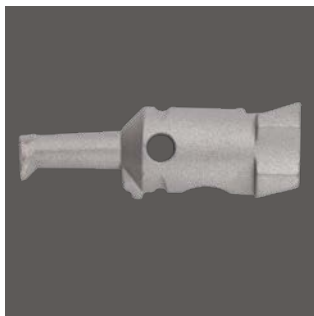

Drilling tools

The feature setting KEIL undercut drilling tools apart is their exact hole geometry in combination with minimum drilling time and maximum tool life. The tools are part of the KEIL undercut system, which may only be used as a whole.



Drilling technique

The comprehensive KEIL drilling technique consists of a full range of machinery for all kinds of application purposes, from handheld drilling machines up to industrial drilling and from drilling tables with roller conveyors to automatic drilling machines.

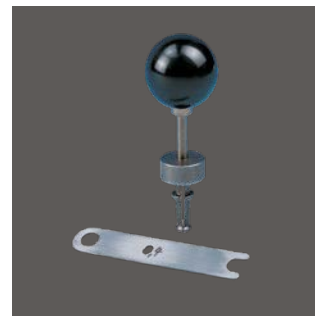

Assembly aids

Our range of KEIL assembly aids offers measuring devices such as depth control guides and feeler gauges for controlling the drill hole geometry as well as screw drivers, torque wrenches, tool sets and further carefully selected work and machine accessories.

KEIL – SERVICE

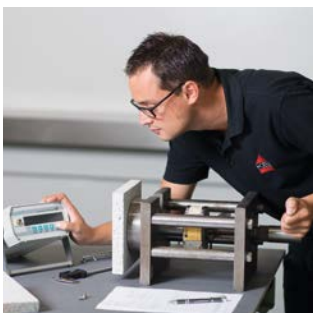

Pull-out tests



Support for approvals



Recommendations on handling and implementation / training



Drilling and Rental service



Please find our current overview of relevant documents on planning permissions under www.keil-fixing.de/en/approvals.

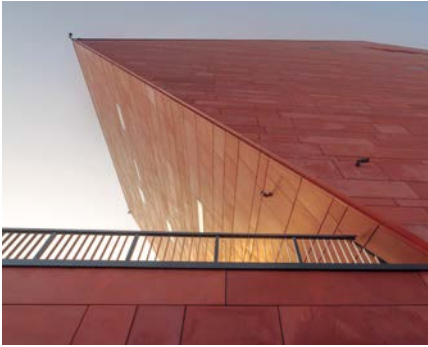

Museum of WW II, Gdańsk, PL © Kwadrat Gdyni



Buddhist Temple, Christchurch, NZ © KEIL

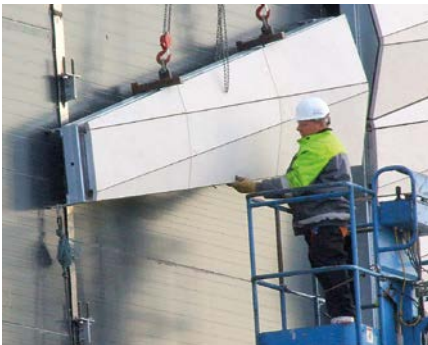

Museum of Liverpool, Liverpool, GB © Vincent Phillips

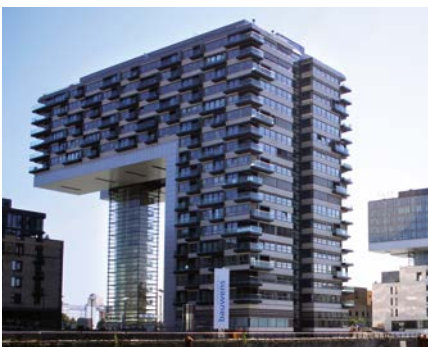

Pandion Vista, Cologne, DE © KEIL

Quality and safety

- ▶ Highest safety owing to a wide range of patents and approvals, e.g. European Technical Approvals (ETA) for the attachment of façade panels.
- ▶ Highest quality MADE IN GERMANY using material A4.
- ▶ Complete system, approved by building inspectorate, sophisticated, highly tried and trusted.
- ▶ Hurricane proof and earthquake tested up to magnitude 9.4 on the open-ended Richter scale.
- ▶ Proven in climate zones all over the world.
- ▶ Non-combustible, mechanical and permanently safe attachment guarantees highest retention force without stress on the façade panel.
- ▶ Higher pull-out load for the same panel thickness than with conventional systems, which support the edges of the panel.

Assembly

- ▶ Highest assembly safety for the façade company due to a self-controlling system: The KEIL undercut anchor can only be mounted into a correctly drilled hole.
- ▶ Short lead time due to an easily established and clearly defined drilling and assembly process.
- ▶ Contrary to many alternative systems, a certification of the operators will not be necessary.
- ▶ Assembly independent of temperature, climate and weather conditions.
- ▶ The possibility of a high level of prefabrication allows for an assembly independent of place and time.
- ▶ Approved and uncomplicated fixing of reveal panels.
- ▶ Tolerances in panel thickness can be balanced automatically by spacer discs.
- ▶ Precise drilling technique (façade drill rotates at 10.000 rpm. in a deflected condition) guarantees a drill hole of a consistent geometry.
- ▶ Optimal use of the technical material characteristics due to a variable position of the undercut anchors.
- ▶ The panel will not be pierced.

Efficiency

- ▶ All required thermal resistances in new buildings and modernisation can be implemented, guaranteeing a pronounced energy efficiency.
- ▶ Due to the constructional separation of insulation and weatherproofing all used materials can be separated and recycled, should the construction be dismantled later on.
- ▶ Subsequent replacement of façade panels e.g. for repairs.
- ▶ Thin façade panels from a thickness of 6 mm onwards – economic and resource-friendly.
- ▶ Assembly of anchor and bracket in one process on the building site.
- ▶ Economical transport of the drilled panels without protruding fixing elements.

Advantages of the system

- ▶ Bigger façade panels of the same thickness can be attached with undercut anchors than with fixing devices according to DIN 18516-3.
- ▶ Breaking loads are up to seven times higher than with attachments on the edge of the panel (e.g. pin anchors).
- ▶ Minimisation of bending stress in the façade panel in comparison to attachments on the edge of the panel.
- ▶ Stress is not reduced to the edges of the panel, as common with pin attachment.

Design and aesthetics

- ▶ Creativity has no limits. Be it elegant, traditional, modern, delicate or unconventional – even the boldest façade ideas can be implemented and allow for free planning.
- ▶ The façade shows a clean, uninterrupted image without visible fixing points.
- ▶ More than 50 different panel materials are available, e.g. ceramics, porcelain stoneware, natural stone, synthetic materials/HPL, fibre cement, glass fibre reinforced concrete, glass ceramics, artificial stone, UHPC, polymer concrete, solid surface materials or glass.
- ▶ Combinations and alternations of different materials, shapes and colours are possible and assist in implementing planned effects.
- ▶ Variable panel formats.
- ▶ Closed or open joints without visible anchors are distinctive of high quality façades.
- ▶ Due to the attachment on the back side of the panel, there will be no dirt or rust streaks.
- ▶ In comparison to the attachment on the edge of the panel, larger sized panels can be fixed with a high safety level.
- ▶ Your property will increase in value in regard to acceptance and marketing.
- ▶ Technical equipment can be integrated behind the façade, e.g. lighting, sun protection, supply cables, gutters, lightning protection, security systems.
- ▶ Aesthetics and energy efficiency are not mutually exclusive.



Vanke Pavilion (EXPO 2015), Mailand, IT © Hutton + Crow, Studio Libeskind



Penthouse, Hamburg, DE © Klaus Stemmler, Material: HI-MACS® - Design: Gerdt Architektur - Fabrication: Kiebitzberg GmbH & Co.KG

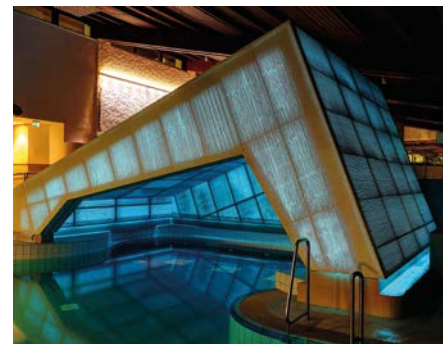

Obermaintherme, Bad Staffelstein, DE © LUCEM light transmitting concrete



Alice Trully Hall, New York, US © KEIL

Sophisticated and approved by building authorities

Undercut attachments for façade panels in ventilated rainscreens are nowadays state-of-the-art. The Deutsches Institut für Bautechnik (DIBt; German institute for building technique) drew up an approval concept for this purpose.

General building approvals

General building approvals will be granted for construction products and techniques within the scope of state regulation for which there are no generally acknowledged technical regulations, especially DIN norms, or which differ from them in a significant way. They are reliable verifications of applicability of construction products resp. of types of construction in regard to constructional requirements of buildings.

European Technical Assessments

European Technical Assessments (ETA) will be issued for construction products in the scope of the EU Construction Products Regulation. They evaluate the performance of a construction product.

Ventilated rainscreens

For a ventilated rainscreen (VHF), the cladding will not be applied directly onto the masonry, but mounted onto a substructure. Thus, insulation (moisture, thermal, sound and fire protections) and weather protection are constructionally separated. This method creates a ventilation space between the components, which regulates the moisture balance within the building structure.

Today's ventilated rainscreens are amongst the most successful façade systems. Current studies of the façade market verify that, besides its functional safety, architects most highly appreciate the creative possibilities of a ventilated rainscreen.

The system of the ventilated rainscreen allows for a choice of the most different claddings. Therefore, the design of the façade can be individually matched to the characteristics of a building. Even combinations of different materials can be easily implemented – by the use of different cladding materials.

Due to their enormous freedom of design, – e.g. concerning colour, material surface – ventilated rainscreens offer a special identity for buildings and their inhabitants. They can be easily planned and sustainably incorporated into the overall concept of the assessment of the life cycle.

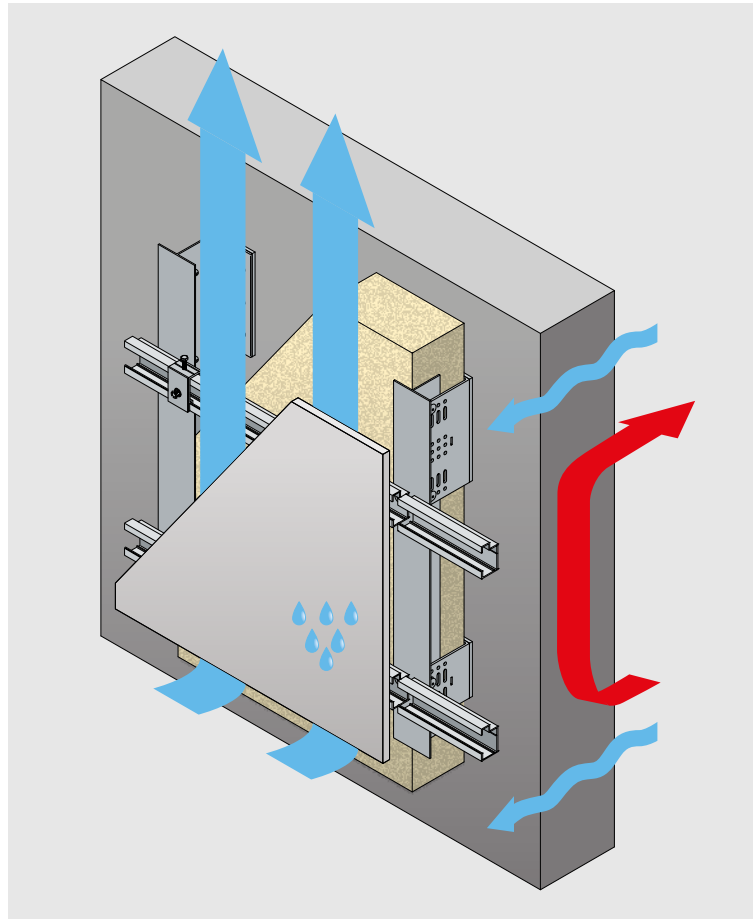

Title: Sapphire, Berlin, DE © André Baschakow, Berlin www.baschakow-fotografie.de

Fachverband
Baustoffe und
Bauteile für
vorgehängte
hinterlüftete
Fassaden e.V.
(FVHF)

Sponsoring member:

DEUTSCHE NATURSTEIN AKADEMIE

Deutscher
Naturwerkstein-
Verband e.V.

Member:

DEUTSCHES
WERKZEUG

Associate member:

KEIL Befestigungstechnik GmbH

Im Auel 42 . 51766 Engelskirchen
Germany

P.O. Box 11 58 . 51751 Engelskirchen
Germany

Phone: +49 2263 807-0
Fax: +49 2263 807-333
Mail: mail@keil-fixing.de